

⚠ WARNING



Electrical Shock Hazard

Disconnect power before servicing.
Replace all panels before operating.
Failure to do so can result in death or electrical shock.

PRECAUTIONS TO BE OBSERVED BEFORE AND DURING SERVICING TO AVOID POSSIBLE EXPOSURE TO EXCESSIVE MICROWAVE ENERGY

- a. Do not operate or allow the oven to be operated with the door open.
- b. Make the following safety checks on all ovens to be serviced before activating the magnetron or other microwave source, and make repairs as necessary:
 1. Interlock Operation
 2. Proper Door Closing
 3. Seal and Sealing Surfaces (Arcing, Wear & Other Damage)
 4. Damage to or Loosening of Hinges & Latches
 5. Evidence of Dropping or Abuse
- c. Before turning on microwave power for any service test or inspection within the microwave generating compartments, check the magnetron, waveguide or transmission line and cavity for proper alignment, integrity and connections.
- d. Any failed or misadjusted components in the interlock, monitor, door seal, and microwave generation, and transmission systems shall be repaired, replaced, or adjusted by procedures described in service manual before the oven is released to the owner.
- e. A microwave leakage check to verify compliance with the Federal performance standard should be performed on each oven prior to release to the owner.
- f. Do not attempt to operate the oven if the door glass is broken.

Electrostatic Discharge (ESD) Sensitive Electronics

ESD problems are present everywhere. ESD may damage or weaken the electronic control assembly. The new control assembly may appear to work well after repair is finished, but failure may occur at a later date due to ESD stress.

- Use an anti-static wrist strap. Connect wrist strap to green ground connection point or unpainted metal in the appliance - **OR** - touch your finger repeatedly to a green ground connection point or unpainted metal in the appliance.
- Before removing the part from its package, touch the anti-static bag to a green ground connection point or unpainted metal in the appliance.
- Avoid touching electronic parts or terminal contacts; handle electronic control assembly by edges only.
- When repackaging failed electronic control assembly in anti-static bag, observe above instructions.

DIAGNOSTICS

Disconnect power and perform the following checks:

- The most common cause for control failure is corrosion on connectors. Therefore, disconnecting and reconnecting wires will be necessary throughout test procedures.
- Check all connections before replacing components, looking for broken or loose wires, failed terminals, or wires not pressed into connectors far enough.
- All tests/checks should be made with a VOM or DVM having a sensitivity of 20,000 ohms per volt DC or greater.
- Voltage checks **must** be made with all connectors **attached** to the boards.
- Resistance checks **must** be made with power cord unplugged from outlet, and with wiring harness or connectors **disconnected**.

Fahrenheit (° F) to Celsius (° C) Conversion

The default is Fahrenheit (° F).

1. Press the BROIL pad for 5 seconds. The temperature will be displayed in degrees Celsius indicated by the "C" in the temperature display.
2. To return the display to degrees Fahrenheit press the BROIL pad again for 5 seconds. "F" will show in the temperature display.

PROBLEM: Bake Temperature Needs Adjustment

1. Press BAKE pad for 5 seconds. The default temp. 0° or a previously entered offset temp. will show in the Temp. Display.

Press the TEMP pad “up” arrow (⬆) to increase the temperature in 10° F or 5° C increments.

Press the TEMP pad “down” arrow (⬇) to decrease the temperature in 10° F or 5° C increments.

Maximum offset temperature adjustment is ±30° F or ±15° C.

2. Press the START pad to save the temp. adjustment.

Microwave Oven Power Output Test

The power output of the magnetron can be measured by the following test: (for accurate results, the line voltage must be 120 VAC and the oven cavity must be clean).

1. Fill a glass measuring cup with 16 oz. (453cc) of tap water. Stir the thermometer through the water until the temperature stabilizes.
2. Place the cup of water in the center of the oven. Operate on HIGH for 60 seconds.
3. Stir the thermometer through the water and record the maximum temperature.

4. Subtract the cold water temperature from the hot water temperature. The normal result should be a 20 - 38° F (11.1 - 21.1° C) rise in temperature.

NOTE: Less than a 20° F (11.1° C) temperature rise may indicate an operating voltage of less than 110 volts or a low power output from the magnetron. Cooking time can be adjusted to compensate for either circumstance. Replace the magnetron only if the water temperature rise indicates a power output well beyond the normal result.

Programming the Cavity Size

When replacing the electronic control, be sure to program the cavity size:

1. Within 60 seconds of power up, press the following touchpads:
OVEN CANCEL, WARM HOLD, BAKE, TEMP DOWN, TIMER OFF, MINUTE DOWN, MICRO CANCEL, 5, OVEN START/ENTER, OVEN LIGHT.
2. Size is shown in display - Id: 24".
3. Press CLOCK pad until correct size is displayed.
4. Press CANCEL.
5. Press and hold OVEN CANCEL pad for 5 seconds to verify programming.

OVEN SHUTDOWN THERMAL FUSE

The oven shutdown thermal fuse is located at the back of the oven. It will shut down the elements if the temperature at the back of the oven exceeds component limits.

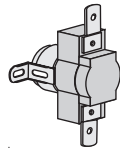

Verify that the oven shutdown thermal fuse is okay.

To replace this thermal fuse, refer to chart at right for correct part number.

Thermal Fuse Part No.	Opening Temp. °C	Reclose Temp. °C	Marking (with Black Letters)
4452223	130°C ± 5.5°C	-35°C MAX	Pink/Wht Stripe
4451442	120°C + 10°C to 120°C - 0°C		Yellow/Wht Stripe
4450934	170°C ± 6.5°C		Red
4450334	135°C ± 6.5°C		Orange/Wht Stripe
4450250	160°C ± 6.5°C		Blue
4450249	150°C ± 6.5°C		Green/Wht Stripe
8300802	110°C + 10°C to 110°C - 0°C		Blue/Wht Stripe

FAILURE/ERROR DISPLAY CODES

NOTES:

- Always disconnect power before touching internal parts of the oven!
- Upon replacement, immediately return old electronic oven control using the mailing label supplied with each new control.

FAULT CODE	ERROR CODE	MEANING OF FAILURE CODE	RECOMMENDED REPAIR PROCEDURE
F0		Default F code - no failure	Will only be displayed if user presses and holds OVEN CANCEL key for 5 seconds and there are no pre-existing faults. Press CANCEL to clear display.
F1	All E Codes	Electronic control malfunction	Replace control.
F2	E0	Key held down too long or key is shorted	<ol style="list-style-type: none"> 1. Check keypad connector for firm connection. 2. Press CANCEL. If error code returns after 60 sec., replace keypad. 3. If fault persists replace control.
	E1	Keypad keytail not connected	
	E5, E6	CANCEL key drive line open	
F3	E0	Temperature sensor opened	<ol style="list-style-type: none"> 1. Check sensor connection. 2. Measure sensor resistance (1080 Ω at 21° C [70° F]. Add 2 Ω per degree F) 3. If resistance is not valid replace sensor. 4. If sensor resistance and connections are good, then check for welded-closed relays on the control.
	E1	Temperature sensor shorted	
	E2	Oven temp too high - over 301° C (575° F) in COOK mode	
	E3	Oven temp too high - over 510° C (950° F) in CLEAN mode	
F5	E0	Door is open, but latch is locked (condition exists when door switch is closed indicating an open door, and latch switch is closed indicating a locked door).	<ol style="list-style-type: none"> 1. Check the latch assembly: latch arm pivot joint, arm/solenoid connection, solenoid spring, and spring washer. 2. Check the Latch Solenoid: <ul style="list-style-type: none"> - Check for firm electrical connections. - Disconnect the two wires from the solenoid and measure the resistance of the solenoid. A small resistance (approx. 175Ω) is normal. If the solenoid is open ($\infty\Omega$) or shorted (0Ω), it should be replaced. 3. Check the Latch Switch. Disconnect it and use a continuity tester: <ul style="list-style-type: none"> Door latched = switch closed, continuity should read 0Ω. Door unlatched = switch open, continuity should read $\infty\Omega$. 4. Check Door Open/Closed Switch. Disconnect it and use a continuity tester: <ul style="list-style-type: none"> Door open = switch closed, continuity should read 0Ω. Door closed = switch open, continuity should read $\infty\Omega$. 5. Check power and element connections.
	E1	Self-clean latch will not lock	
	E5	Self-clean temperature 288° C (550° F) not reached within 45 min.	
	E7	Self-clean latch will not unlock	
F6	E0	Return line not connected	If switch pulse return line not connected, electronic control will display F6 within 60 seconds after power up. Replace control.

WIRE HARNESS SCHEMATIC

NOTES:

- When replacing the electronic control, be sure to program the cavity size. See "Programming the Cavity Size" on page 2.
- Dots indicate connections or splices.
- Circuit shown in STANDBY/OFF mode with microwave oven door and lower oven door **OPEN**.

T.O.D. (RESETTABLE)		LIGHT		HEATING ELEMENT	
THERMAL FUSE/T.O.D. (NON-RESETTABLE ONE TIME)		AC DRIVE MOTOR		SOLENOID	
GROUND (CHASSIS)		RELAY COIL		ENCLOSED THERMISTOR	
PLUG WITH FEMALE CONNECTOR		RELAY CONTACTS		OPERATED BY DOOR	
RECEPTACLE WITH MALE CONNECTOR					

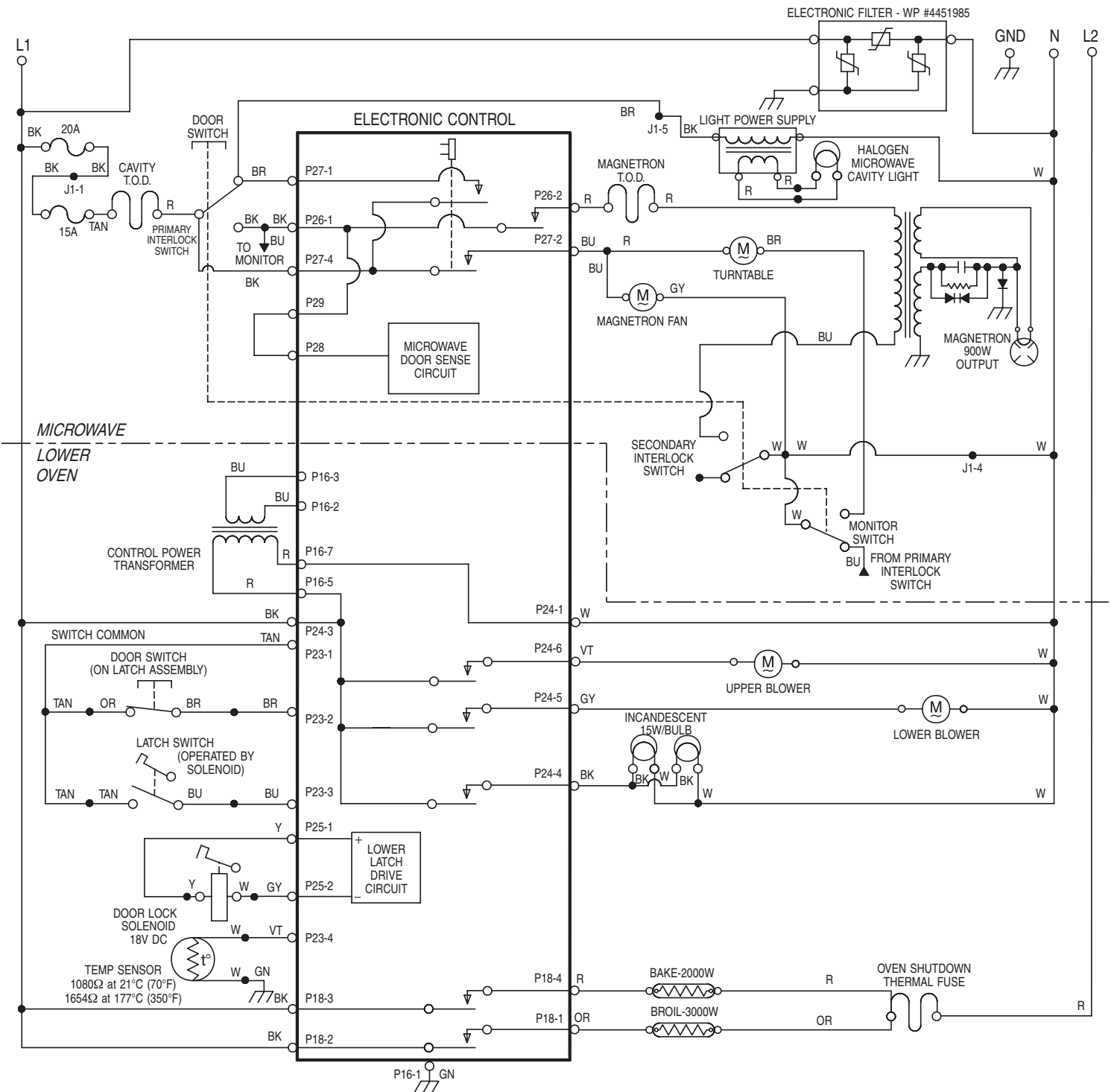

OVEN STRIP CIRCUITS

The following individual circuits are for use in diagnosis.
Before starting diagnosis, check the line voltage and for blown fuses.

BAKE AND PREHEAT-BAKE

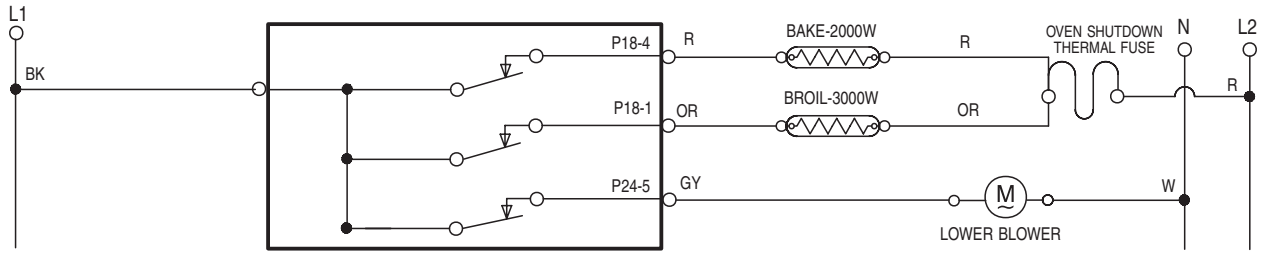

BROIL

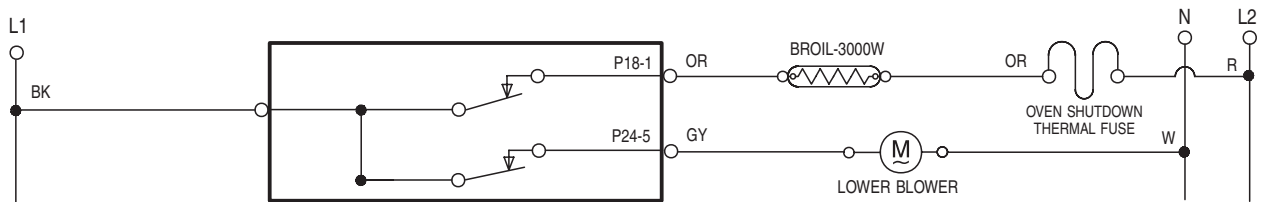

CLEAN AND PREHEAT-CLEAN

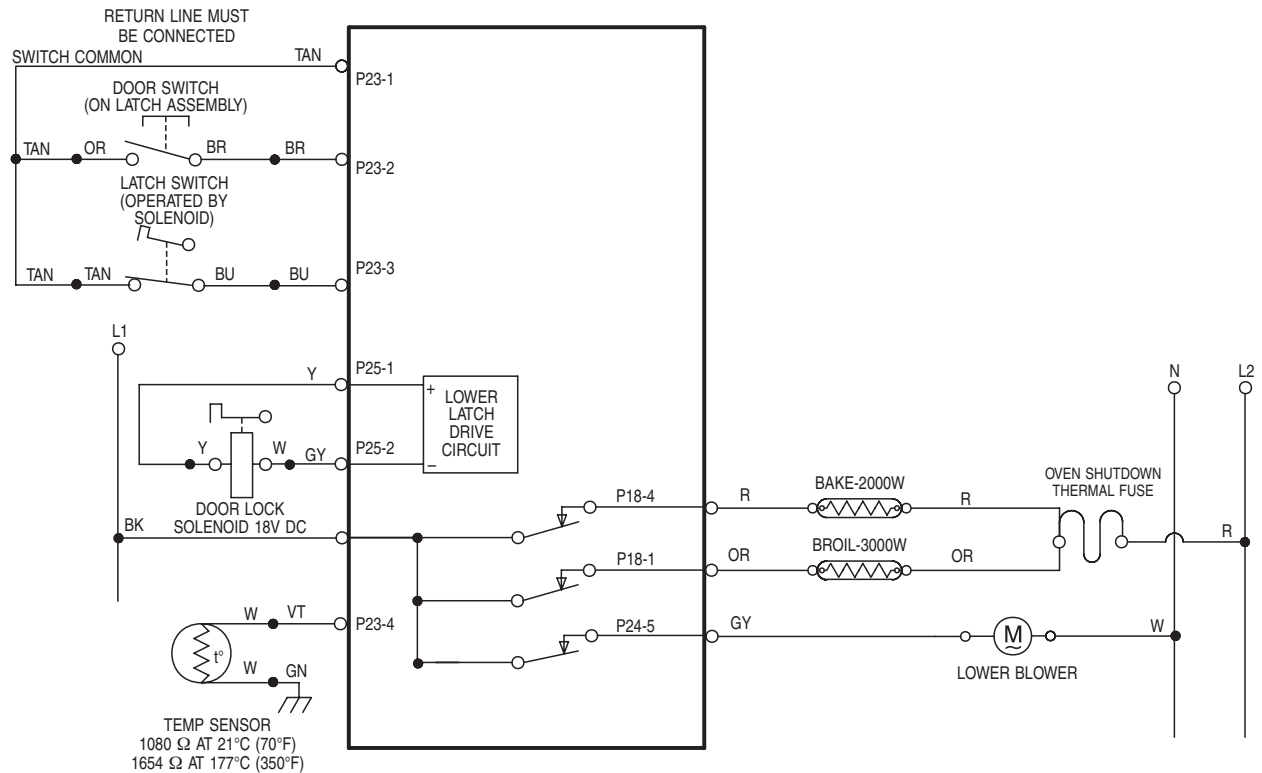

MICROWAVE STRIP CIRCUIT

The following individual circuit is for use in diagnosis.
 Before starting diagnosis, check the line voltage and for blown fuses.

MICROWAVE FULL POWER / VARIABLE POWER

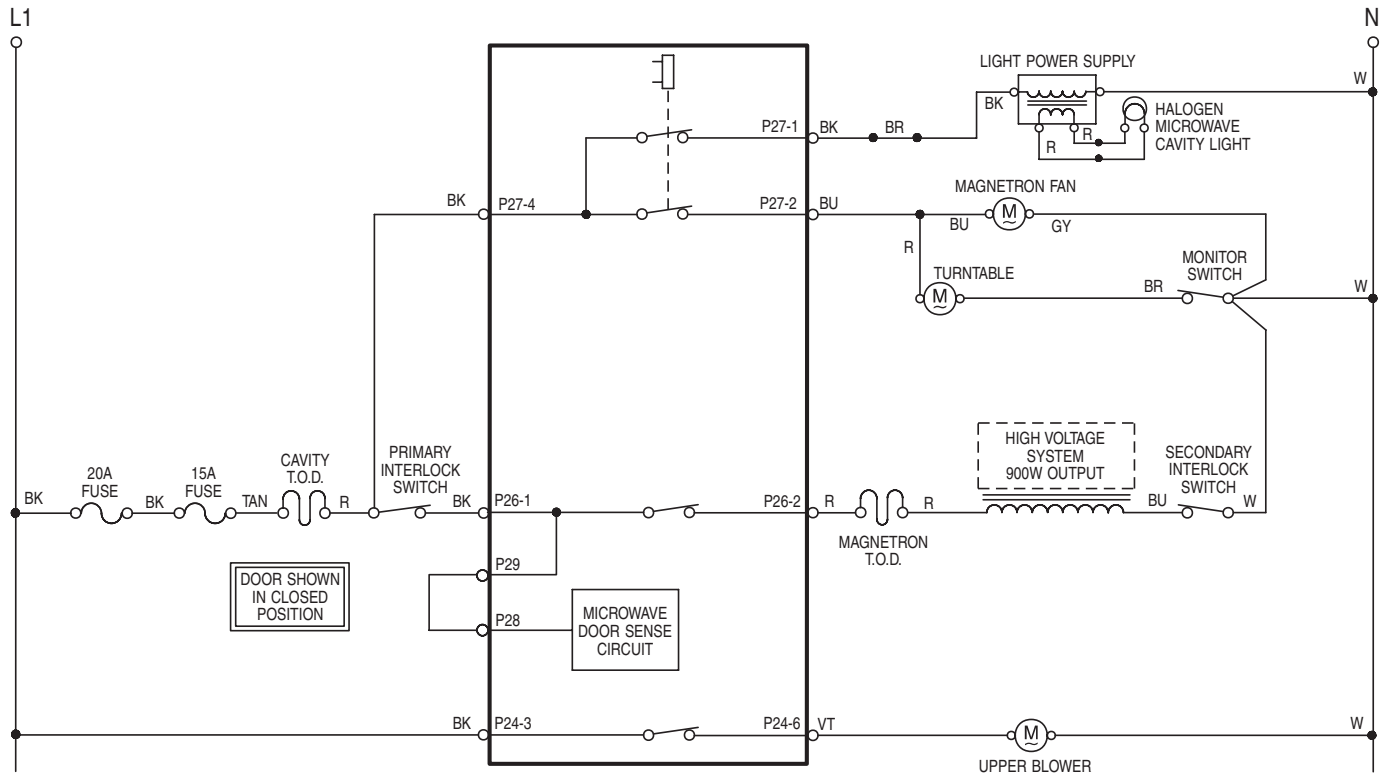

RELAY LOGIC MICROWAVE OVEN

MODES	RELAYS	MAG.	MAG FAN	LIGHT	UPPER BLOWER	LOWER BLOWER
MICRO. FULL PWR	X	X	X	X	⊗	
MICRO. VAR. PWR	△	X	X	X	⊗	
OFF	○	○	⊗	⊗	⊗	

RELAY LOGIC KEY

- - OFF
- X - ON
- △ - CYCLING (Max. Period = 23 sec.)
- + - CYCLING (Max. Period = 60 sec.)
- ⊗ - ON OR OFF

RELAY LOGIC LOWER OVEN

MODES	RELAYS	BAKE	BROIL	OVEN LIGHT	UPPER BLOWER	LOWER BLOWER
OFF	○	○	⊗	⊗	⊗	
BAKE ■		+	+	⊗	X	X
BROIL ●		○	X	⊗	X	X
CLEAN ▲		+	+	○	X	X
■ PREHEAT-BAKE		+	+	⊗	X	X
▲ PREHEAT-CLEAN		+	+	○	X	X
● PREHEAT-BROIL		○	X	⊗	X	X

* IF LOWER IS IN CLEAN MODE,
 MICROWAVE WILL NOT FUNCTION.

COMPONENT	FRONT/TOP/REAR SERVICEABLE	CAN BE TESTED AT CONTROL PANEL	
		CHECK POINTS	RESULTS
Electronic Control	Front	—	—
Control Transformer	Top	—	—
Electronic Filter	Top	—	—
Membrane Switch	Front	—	—
Incandescent Lights	Light Bulb - Front Light Assy. - Rear	—	—
Latch Solenoid	Front	—	—
Latch Switch	Front	P23-3 (BU) to P23-1 (TAN)	Door Unlocked = Open Circuit Door Locked = Closed Circuit
Door Switch	Front	P23-2 (BR) to P23-1 (TAN)	Door Open = Closed Circuit Door Closed = Open Circuit
Door Lock Solenoid (with Door Closed)	Front	P25-2 (GY) to P25-1 (Y)	50 Ω
Oven Temperature Sensor	Front	P23-4 (VT) to Ground	1080 Ω @ 70° F
Lower Oven Blower	Rear	P24-5 (GY) to Neutral (W)	14 Ω to 18 Ω
Oven Shutdown Thermal Fuse	Rear	P2-4 (R) or P3-1 (OR) to Red Wire at Terminal Block	Closed Circuit
Bake Element (2000 Watt)	Front	P18-4 (R) to Red Wire at Terminal Block	25 Ω to 30 Ω
Broil Element (3000 Watt)	Front	P18-1 (OR) to Red Wire at Terminal Block	32 Ω to 35 Ω
Microwave Light Transformer (M/W)	Top	Primary Winding	40 Ω to 45 Ω
		Secondary Winding	Less than 1 Ω
Upper Blower (M/W)	Rear	P24-6 (VT) to Neutral (W)	10 Ω to 15 Ω

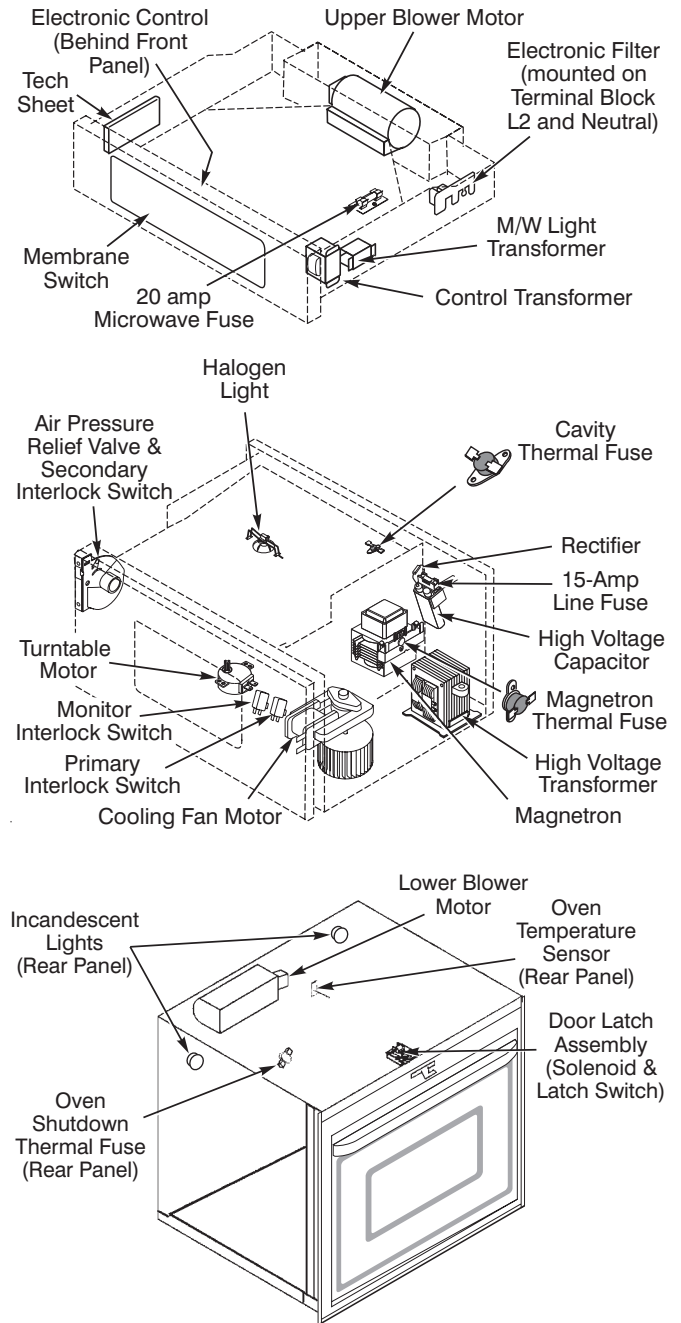

COMPONENT LOCATIONS

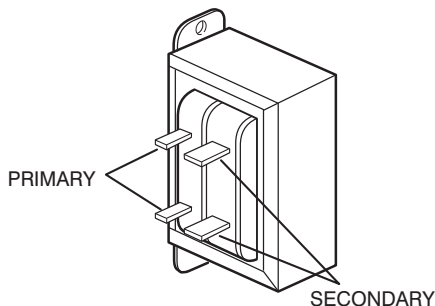

CONTROL TRANSFORMER

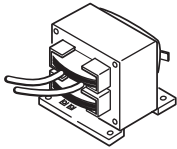
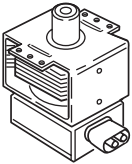
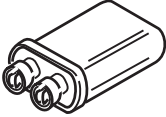
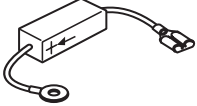
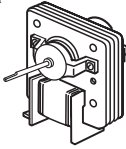
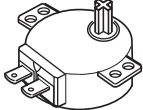

Testing the Microwave Oven Components

COMPONENT	TEST PROCEDURE	RESULTS									
 HIGH VOLTAGE TRANSFORMER	1. Remove the leads from the terminals. 2. Set the ohmmeter to R x 1 and touch the leads to the terminals. Primary Secondary Filament to Ground 3. Measure resistance (R x 100) Primary Filament	Normal = Less than 1 Ω. Normal = Less than 1 Ω. Normal = 0 Ω. Normal = Infinity. Normal = Infinity.									
 MAGNETRON	1. Remove the leads from the terminals. 2. Set the ohmmeter to R x 1 and touch the leads to the F and FA terminals. 3. Set the ohmmeter to R x 1000 and measure filament to chassis.	Normal = approximately 0 Ω. Normal = Infinity.									
 CAPACITOR	1. Remove the leads from the terminals. 2. Set the ohmmeter to R x 1000 and touch the leads to the terminals. 3. Terminal to chassis.	Normal = Momentarily indicates several ohms, and gradually returns to infinity. Normal = Infinity.									
 RECTIFIER	1. Remove the leads from the terminals. 2. Set the ohmmeter to R x 1000 and measure forward resistance. 3. Measure the reverse resistance. NOTE: Some inexpensive meters may show infinity in both directions.	Normal = Continuity. Abnormal= Infinity. Normal = Infinity. Abnormal = Continuity.									
 FAN MOTOR	1. Remove the leads from the terminals. 2. Set the ohmmeter to R x 1 and touch the leads to the terminals.	Normal = approximately 25 Ω. Abnormal = Infinity.									
 TURNTABLE MOTOR	1. Remove the leads from the terminals. 2. Set the ohmmeter to R x 1 and touch the leads to the terminals.	Normal = approximately 25 Ω. Abnormal = Infinity.									
 Cavity Thermal Fuse	 Magnetron Thermal Fuse	1. Remove the leads from the terminals. 2. Set the ohmmeter to R x 1 and touch the leads to the terminals.									
		<table border="1"> <thead> <tr> <th></th> <th>Open</th> <th>Close</th> </tr> </thead> <tbody> <tr> <td>Cavity Thermal Fuse</td> <td>165°C (329°F)</td> <td></td> </tr> <tr> <td>Mag Thermal Fuse</td> <td>145°C (293°F)</td> <td>125°C (257°F)</td> </tr> </tbody> </table>		Open	Close	Cavity Thermal Fuse	165°C (329°F)		Mag Thermal Fuse	145°C (293°F)	125°C (257°F)
	Open	Close									
Cavity Thermal Fuse	165°C (329°F)										
Mag Thermal Fuse	145°C (293°F)	125°C (257°F)									
		Normal = Continuity. Abnormal = Infinity.									

PART NO. 4455474 REV. D

NOTE: This sheet contains important Technical Service Data

**FOR SERVICE TECHNICIAN ONLY
DO NOT REMOVE OR DESTROY**

MANUFACTURED UNDER ONE OR MORE OF THE FOLLOWING UNITED STATES PATENTS:

4,102,322 4,364,589 4,467,184

OTHER PATENTS PENDING