 WARNING	
	Electrical Shock Hazard
	Disconnect power before servicing.
	Replace all panels before operating.
Failure to do so can result in death or electrical shock.	

DIAGNOSTICS

Before servicing, perform the following checks:

- The most common cause for control failure is corrosion on connectors. Therefore, disconnecting and reconnecting wires will be necessary throughout test procedures.
- All tests/checks should be made with a VOM or DVM having a sensitivity of 20,000 ohms per volt DC or greater.
- Check all connections before replacing components, looking for broken or loose wires, defective terminals, or wires not pressed into connectors far enough.
- Voltage checks **must** be made with all connectors attached to the boards.
- Resistance checks **must** be made with power cord unplugged from outlet, and with wiring harness or connectors **disconnected**.
- Is oven in "Sabbath Mode"? If so "SAB" will appear in the digital display. Press and hold "6" key for 5 seconds to end Sabbath Mode.

IMPORTANT

Electrostatic Discharge (ESD) Sensitive Electronics

ESD problems are present everywhere. ESD may damage or weaken the electronic control assembly. The new control assembly may appear to work well after repair is finished, but failure may occur at a later date due to ESD stress.

- Use an anti-static wrist strap. Connect wrist strap to green ground connection point or unpainted metal in the appliance
- OR-
- Touch your finger repeatedly to a green ground connection point or unpainted metal in the appliance.
- Before removing the part from its package, touch the anti-static bag to a green ground connection point or unpainted metal in the appliance.
- Avoid touching electronic parts or terminal contacts; handle electronic control assembly by edges only.
- When repackaging failed electronic control assembly in anti-static bag, observe above precautions.

PROBLEM: Bake Temperature Needs Adjustment

1. Press BAKE pad for 5 seconds. The default temp. 0° or a previously entered offset temp. will show in the Temp. Display.
 - Press the TEMP pad "up" arrow (⬆) to increase the temperature in 5° F or 3° C increments.
 - Press the TEMP pad "down" arrow (⬇) to decrease the temperature in 5° F or 3° C increments.

Maximum offset temperature adjustment is ±35° F or ±21° C.
2. Press the START pad to save the temp. adjustment.

Fahrenheit (° F) to Celsius (° C) Conversion

The default is Fahrenheit (° F).

1. Press the BROIL pad for 5 seconds. The temperature will be displayed in degrees Celsius indicated by the "C" in the temperature display.
2. To return the display to degrees Fahrenheit press the BROIL pad again for 5 seconds. "F" will show in the temperature display.

NOTES:

- Always disconnect power before touching internal parts of the oven!
- Upon replacement, immediately return old electronic oven control using the mailing label supplied with each new control.
- For double ovens, the failure code is displayed on the side of the display that corresponds to the oven with faulty part (upper oven = left side of display).



WARNING



Electrical Shock Hazard

Disconnect power before servicing.

Replace all panels before operating.

Failure to do so can result in death or electrical shock.

FAILURE/ERROR DISPLAY CODES

FAULT CODE	ERROR CODE	CODE EXPLANATION	RECOMMENDED REPAIR PROCEDURE
F0		Default F code -no failure	Will only be displayed if user presses and holds "0" key for 5 seconds and there is no pre-existing fault. Press CANCEL to clear display.
F1	E3	Wiring harness cavity size does not match previously stored value	The "Cavity Size Select" jumpers in the wiring harness indicate a cavity size different from that which the control was previously configured for. Check the jumpers in the harness to make sure they agree with the actual oven size.
	All Other E Codes	Electronic control malfunction	Replace control if the E code is not E3.
F2	E0	Keypad not connected	<ol style="list-style-type: none"> 1. Check keypad connector for firm connection. 2. Press CANCEL. If error code returns after 60 sec., replace keypad.
	E3	Key held down too long, or key is shorted	
F3	E0	Temperature sensor opened	<ol style="list-style-type: none"> 1. Check sensor connection. 2. Measure sensor resistance (1080Ω at 70° F. Add 2Ω per degree.) 3. If resistance is not valid, replace sensor. 4. If sensor resistance and connections are good, then the oven cavity temperature must have exceeded a safe level. Check for welded-closed relays on the control.
	E1	Temperature sensor shorted	
	E2	Oven temp too high	
F4	E1	Shorted meat probe	<ol style="list-style-type: none"> 1. Disconnect meat probe and measure probe resistance (78kΩ at 60° F; 37kΩ at 90° F.) 2. If resistance is not valid, replace probe. 3. Insert probe and check for a firm connection between probe and jack (in oven cavity). 4. Check connection between jack and harness (in rear of oven).
F5	E1	Self clean latch will not lock	<ol style="list-style-type: none"> 1. Check the latch assembly: latch arm pivot joint, arm/solenoid connection, solenoid spring, and spring washer. 2. Check the Latch Solenoid: <ul style="list-style-type: none"> - Check for firm electrical connections. - Disconnect the two wires from the solenoid and measure the resistance of the solenoid. A small resistance (approx. 175Ω) is normal. If the solenoid is open ($\infty\Omega$) or shorted (0Ω), it should be replaced. 3. Check the Latch Switch. Disconnect it and use a continuity tester: <ul style="list-style-type: none"> - Door latched = switch closed, continuity should read 0Ω. - Door unlatched = switch open, continuity should read $\infty\Omega$. 4. Check Door Open/Closed Switch. Disconnect it and use a continuity tester: <ul style="list-style-type: none"> - Door open = switch closed, continuity should read 0Ω. - Door closed = switch open, continuity should read $\infty\Omega$.
	E6	Door is open, but latch is locked	
	E7	Self clean latch will not unlock	
F7		Common switch wire is shorted	<p>Common wire (+5VDC) to latch switch, and to door switch is shorted to chassis ground or neutral. A double oven will have two of each switch and one common wire.</p> <ol style="list-style-type: none"> 1. Check connections at control and at the latch switch and door switch. 2. If all connections are good, then check the individual switches as outlined for the F5 failure. 3. Replace control or check harness.

WIRE HARNESS SCHEMATIC

NOTES:

WHEN REPLACING THE ELECTRONIC CONTROL, BE SURE TO ATTACH THE CAVITY SELECT LINE TO THE PROPER TERMINAL (SEE "CAVITY SIZE" TABLE BELOW).

DOTS INDICATE CONNECTIONS OR SPLICES.

CIRCUIT SHOWN IN STANDBY/OFF MODE WITH OVEN DOOR CLOSED.

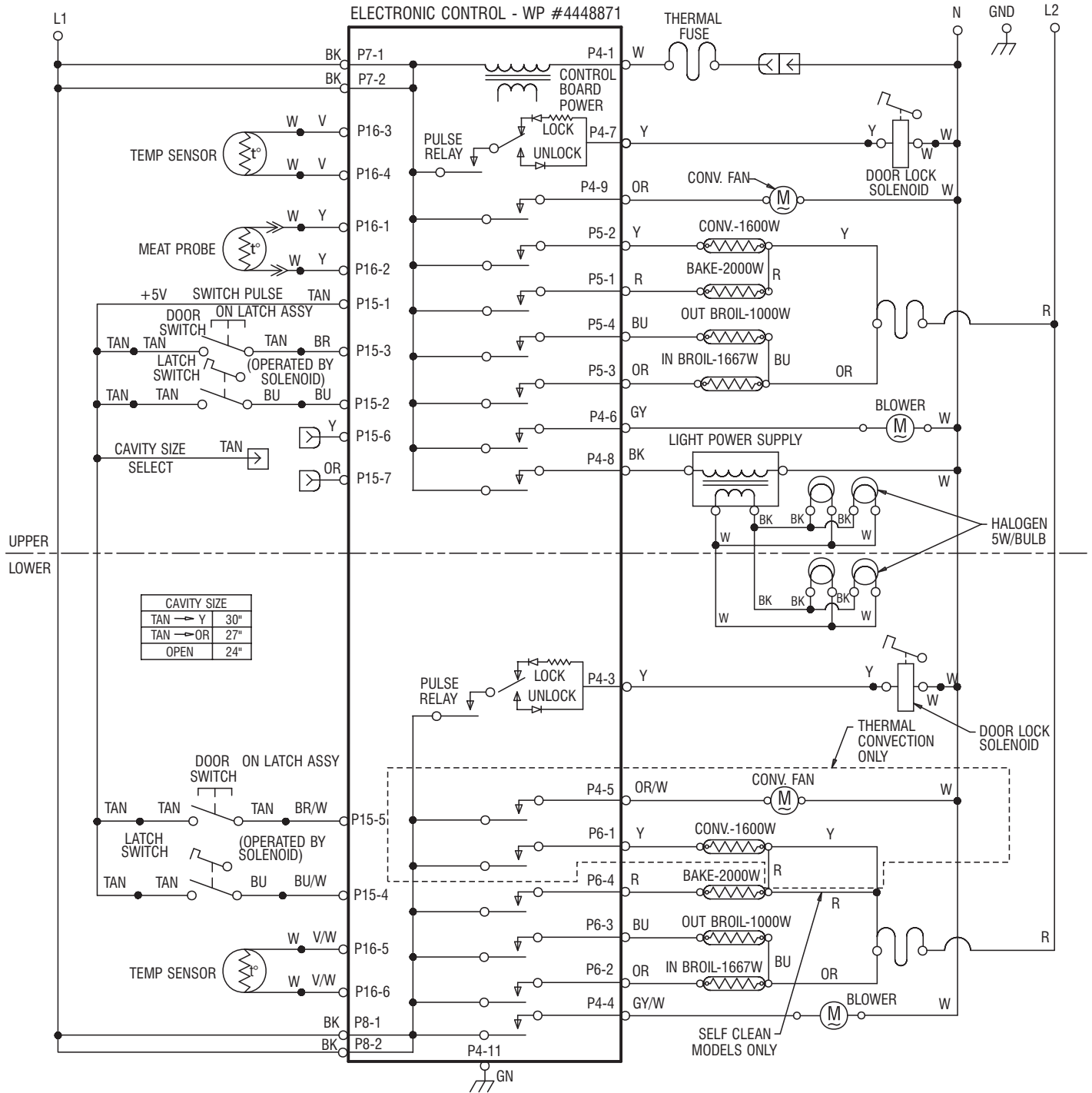
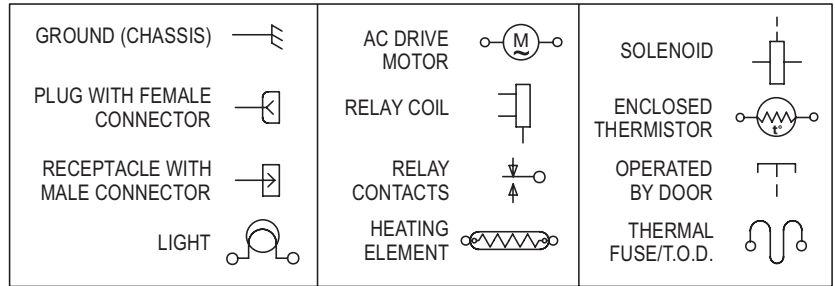

UPPER OVEN COMPONENTS

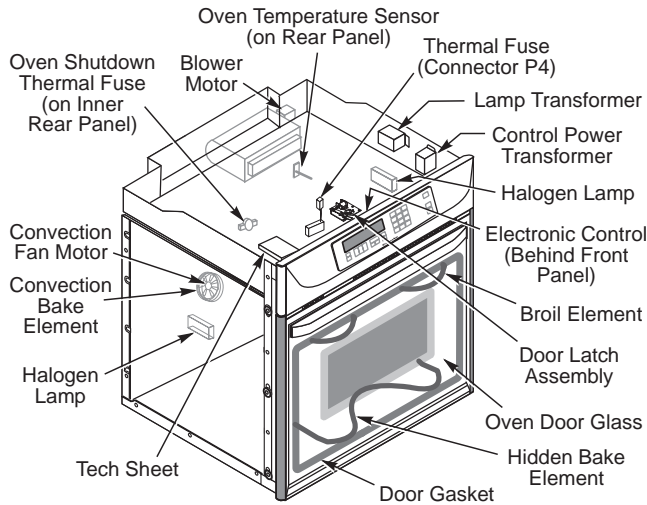

LOWER OVEN COMPONENTS

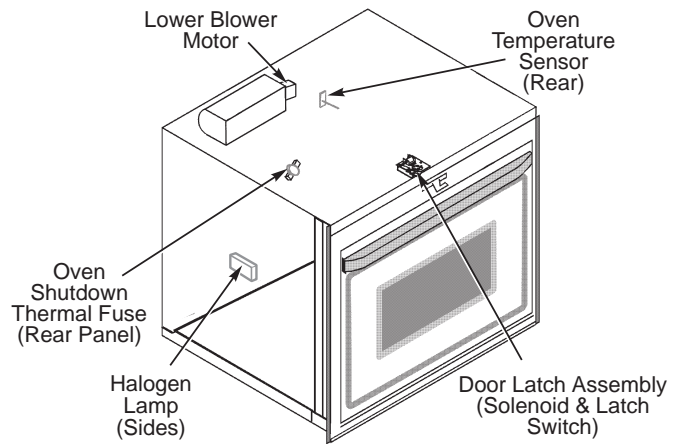

CONTROL POWER TRANSFORMER

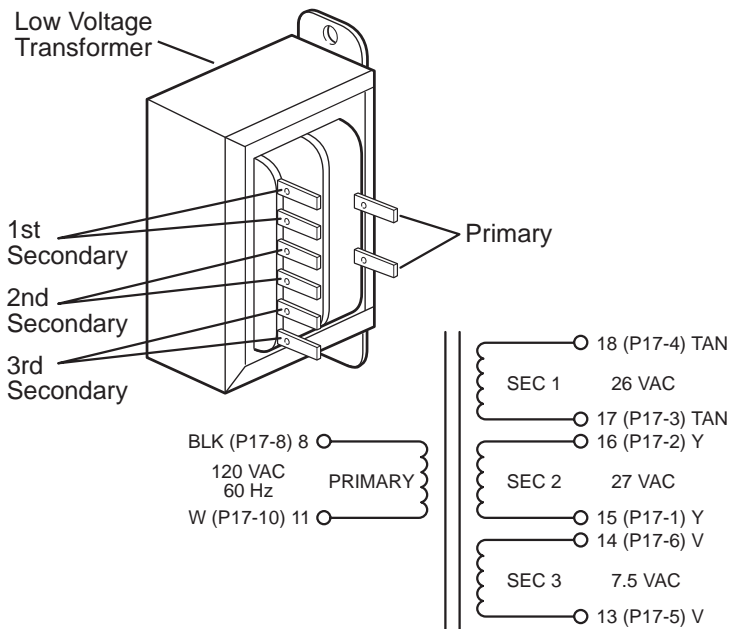

ELECTRICAL COMPONENTS KEY

OVEN COMPONENT	FRONT / REAR SERVICEABLE
ELECTRONIC CONTROL	FRONT
MEMBRANE SWITCH	FRONT
DOOR SWITCHES	FRONT
LATCH SWITCHES	FRONT
LATCH SOLENOIDS	FRONT
MEAT PROBE SENSOR	PROBE - FRONT JACK - REAR
OVEN TEMPERATURE SENSOR	FRONT
CONSOLE BLOWERS	REAR
HALOGEN LIGHTS	LIGHT BULB - FRONT LIGHT ASSY. - REAR
CAVITY LIGHT TRANSFORMER	FRONT
CONVECTION FAN MOTORS	REAR
THERMAL FUSE T.O.D.	REAR
BAKE ELEMENTS	REAR
OUTER BROIL ELEMENTS	FRONT
INNER BROIL ELEMENTS	FRONT
CONVECTION RING ELEMENTS	FRONT
CONTROL POWER TRANSFORMER	FRONT

ELECTRONIC CONTROL PINOUTS

PIN	FUNCTION	COLOR
P5-1	BAKE UPPER	R
ROUND		
P5-2	CONVECTION RING UPPER	Y
P5-3	INNER BROIL UPPER	OR
P5-4	OUTER BROIL UPPER	BU
P6-1	CONVECTION RING LOWER	Y
SQUARE		
P6-2	INNER BROIL LOWER	OR
P6-3	OUTER BROIL LOWER	BU
P6-4	BAKE LOWER	R
P15-1	+5 VOLT SWITCH PULSE	TAN
P15-2	LATCH SWITCH UPPER	BU
P15-3	DOOR SWITCH UPPER	BR
P15-4	LATCH SWITCH LOWER	BU/W
P15-5	DOOR SWITCH LOWER	BR/W
P15-6	30" CAVITY SELECT	Y
P15-7	27" CAVITY SELECT	OR
P4-1	NEUTRAL	W
P4-2	NOT CONNECTED	
P4-3	SOLENOID LOWER	Y
P4-4	COOLING FAN LOWER	GY/W
P4-5	CONVECTION FAN LOWER	OR/W
P4-6	COOLING FAN UPPER	GY
P4-7	SOLENOID UPPER	Y
P4-8	LIGHTS	BK
P4-9	CONVECTION FAN UPPER	OR
P4-10	NOT CONNECTED	
P4-11	EARTH GROUND	GN
P16-1	MEAT PROBE GROUND	Y
P16-2	MEAT PROBE	Y
P16-3	OVEN SENSOR UPPER	V
P16-4	OVEN SENSOR UPPER	V
P16-5	OVEN SENSOR LOWER	V/W
P16-6	OVEN SENSOR LOWER	V/W
P7-1	L1	BK
P7-2	L1	BK
P8-1	L1	BK
P8-2	L1	BK

RELAY LOGIC UPPER AND LOWER OVEN

MODES	RELAYS	BAKE	IN BR	OUT BR	CONV ELEM	CONV FAN	OV LT	BLOWER	PULSE RELAY	LOCK/UNLOCK
OFF	○	○	○	○	○	○	⊗	⊗	○	○
■ PREHEAT-BAKE	X	+	X	○	○	⊗	X	○	○	○
BAKE 24",30" ■	X	○	X	○	○	⊗	X	○	○	○
BAKE 27" ■	+	○	X	○	○	⊗	X	○	○	○
ECONO BROIL	○	X	○	○	○	⊗	X	○	○	○
MAXI BROIL	○	X	X	○	○	⊗	X	○	○	○
CONV BROIL	○	X	X	○	X	⊗	X	○	○	○
● PREHEAT-CONV	X	+	X	○	X	⊗	X	○	○	○
CONV ROAST 24" ●	X	○	X	○	X	⊗	X	○	○	○
CONV ROAST 27",30" ●	X	+	X	○	X	⊗	X	○	○	○
CONV BAKE 24" ●	○	○	○	+	X	⊗	X	○	○	○
CONV BAKE 27" ●	○	○	○	X	X	⊗	X	○	○	○
CONV BAKE 30" ●	+	○	○	X	X	⊗	X	○	○	○
▲ PREHEAT-CLEAN	X	X	X	○	○	○	X	*	*	*
CLEAN ▲	X	+	+	○	○	○	X	○	○	○
PREHEAT DEHYDRATE	○	○	○	+	X	⊗	X	○	○	○
DEHYDRATE	○	○	○	X	X	⊗	X	○	○	○
PREHEAT-BREAD	○	○	○	+	X	⊗	X	○	○	○
RAISING BREAD	○	○	○	+	X	⊗	X	○	○	○

RELAY LOGIC KEY

- KEY
- - OFF
 - X - ON
 - + - CYCLING (MAX PERIOD=90 SEC)
 - ⊗ - ON OR OFF
 - * - PULSED FOR 1/2 SEC

OVEN SHUTDOWN THERMAL FUSE

The oven shutdown thermal fuse is located at the back of the oven. It will shut down the elements if the temperature at the back of the oven exceeds component limits.

Verify that the Oven Shutdown Thermal Fuse is okay.

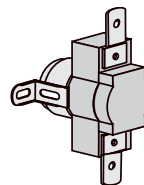

THE FOLLOWING COMPONENTS CAN BE TESTED AT THE CONTROL PANEL:

LOWER OVEN			
COMPONENTS	FRONT/REAR SERVICEABLE	CHECK POINTS	RESULTS
Door Switch	Front	P15-5 (BR/W) to P15-1 (TAN)	Door Open = Closed Circuit Door Closed = Open Circuit
Door Lock Solenoid (with Door Closed)	Front	P4-3 (Y) to Neutral (W)	50 Ω
Oven Temperature Sensor	Front	Sensor P16-5 (V/W) to P16-6 (V/W)	1080 Ω @ 70°F
Blower	Rear	P4-4 (GY/W) to Neutral (W)	14 Ω to 18 Ω
Oven Light Transformer	Front	Primary Winding Secondary Winding	40 Ω to 45 Ω Less than 1 Ω
Oven Shutdown Thermal Fuse	Rear	P6-2 (OR) to Red Wire at Terminal Block	Closed Circuit
Bake Element	Rear	P6-4 (R) to Red Wire at Terminal Block	25 Ω to 30 Ω
Inner Broil Element	Front	P6-2 (OR) to Red Wire at Terminal Block	45 Ω to 55 Ω
Outer Broil Element	Front	P6-3 (BU) to Red Wire at Terminal Block	45 Ω to 55 Ω
Convection Ring Element	Front	P6-1 (Y) to Red Wire at Terminal Block	28 Ω to 35 Ω
Convection Fan Motor	Rear	P4-5 (OR/W) to Neutral (W)	8 Ω to 12 Ω
Latch Switch	Front	P15-4 (BU/W) to P15-1 (TAN)	Door Unlocked = Open Circuit Door Locked = Closed Circuit

UPPER OVEN			
COMPONENTS	FRONT/REAR SERVICEABLE	CHECK POINTS	RESULTS
Door Switch	Front	P15-1 (BR) to P15-3 (TAN)	Door Open = Closed Circuit Door Closed = Open Circuit
Door Lock Solenoid (with Door Closed)	Front	P4-7 (Y) to Neutral (W)	50 Ω
Oven Temperature Sensor	Front	Sensor P16-3 (V) to P16-4 (V)	1080 Ω @ 70°F
Blower	Rear	P4-6 (GY) to Neutral (W)	14 Ω to 18 Ω
Oven Light Transformer	Front	Primary Winding Secondary Winding	40 Ω to 45 Ω Less than 1 Ω
Oven Shutdown Thermal Fuse	Rear	P5-3 (OR) to Red Wire at Terminal Block	Closed Circuit
Bake Element	Rear	P5-2 (R) to Red Wire at Terminal Block	25 Ω to 30 Ω
Inner Broil Element	Front	P5-3 (OR) to Red Wire at Terminal Block	45 Ω to 55 Ω
Outer Broil Element	Front	P5-4 (BU) to Red Wire at Terminal Block	45 Ω to 55 Ω
Convection Ring Element	Front	P5-2 (Y) to Red Wire at Terminal Block	28 Ω to 35 Ω
Convection Fan Motor	Rear	P4-9 (OR) to Neutral (W)	8 Ω to 12 Ω
Meat Probe Jack	Rear	P16-1 (Y) to P16-2 (Y)	Probe into Jack- Check for 78 k Ω @ Room Temp.
Control Panel Thermal Fuse	Front	P4-1 to Neutral (W) Across Fuse	Closed Circuit
Latch Switch	Front	P15-2 (BU) to P15-1 (TAN)	Door Unlocked = Open Circuit Door Locked = Closed Circuit

OVEN STRIP CIRCUITS

The following individual circuits are for use in diagnosis.

Before starting diagnosis, check the line voltage and for blown fuses.

NOTE: Pin numbers and wire colors shown in parentheses () denote lower oven connections.

BAKE

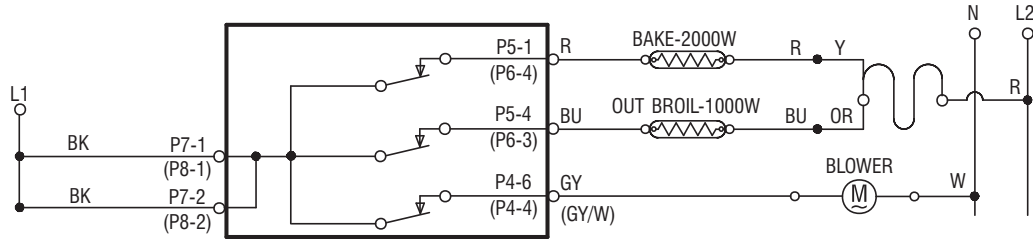

PREHEAT BAKE

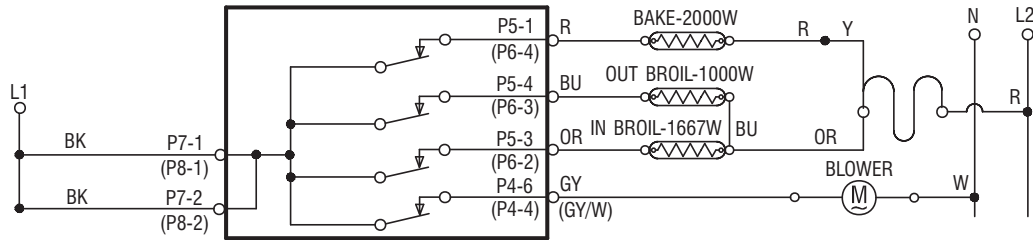

ECONO BROIL

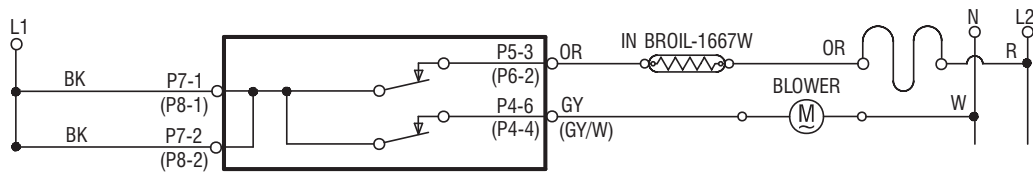

MAXI BROIL

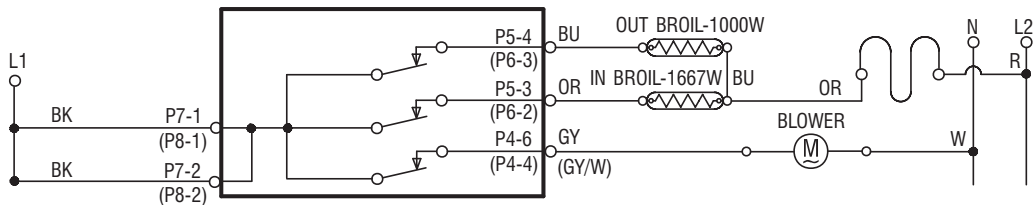

CONVECTION BROIL

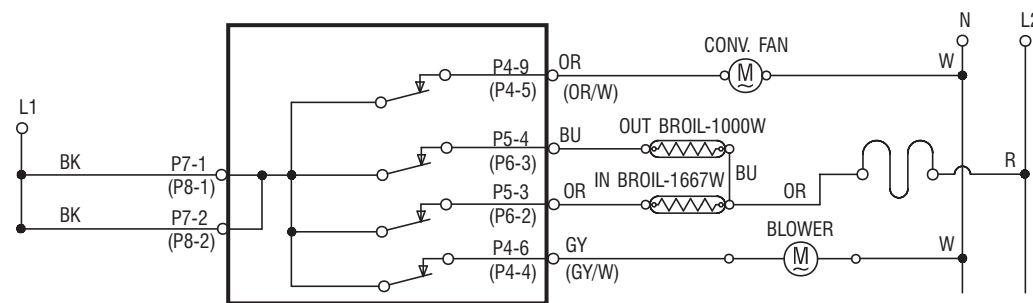

CONVECTION ROAST AND PREHEAT CONVECTION ROAST

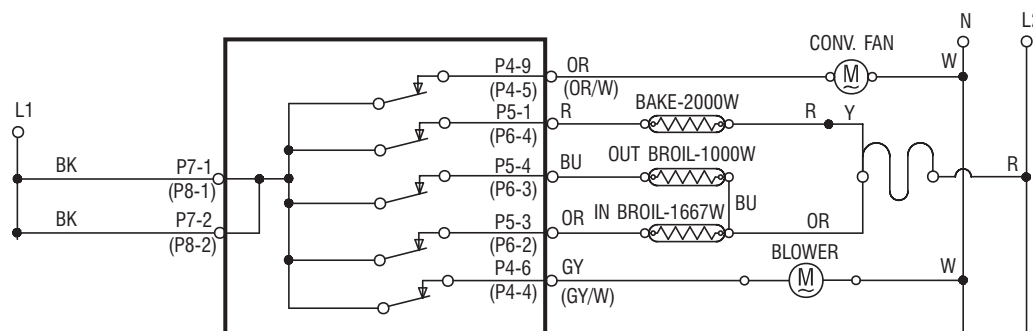

OVEN STRIP CIRCUITS

The following individual circuits are for use in diagnosis.
Before starting diagnosis, check the line voltage and for blown fuses.

NOTE: Pin numbers and wire colors shown in parentheses () denote lower oven connections.

CONVECTION BAKE

(Bake element used only on 30")

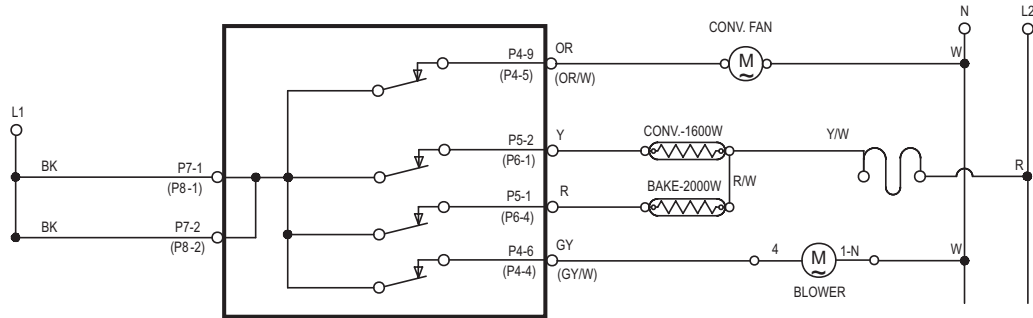

CLEAN

(Above 600°F)

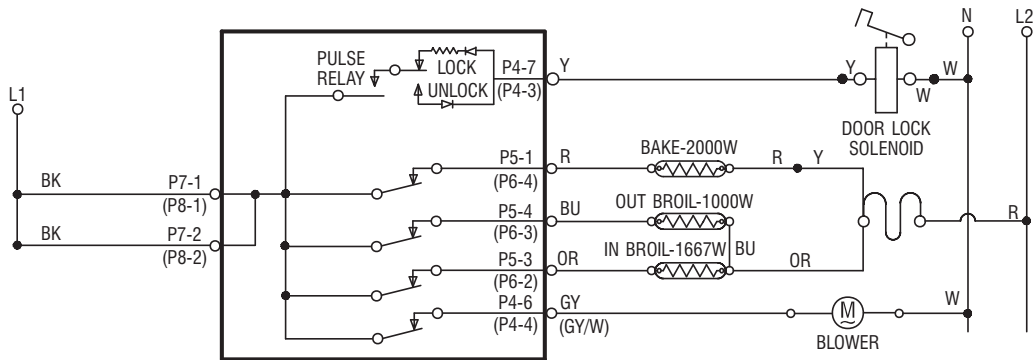

PREHEAT CLEAN

(Below 600°F)

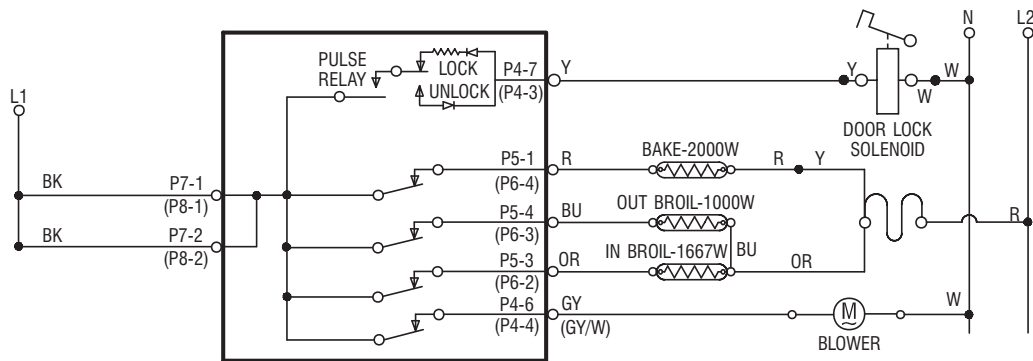

PART NO. 4452026

NOTE: This sheet contains important
 Technical Service Data

**FOR SERVICE TECHNICIAN ONLY
 DO NOT REMOVE OR DESTROY**

MANUFACTURED UNDER ONE OR MORE OF THE FOLLOWING
 UNITED STATES PATENTS:

4,102,322

4,364,589

4,467,184

OTHER PATENTS PENDING